

JACK 杰克

快速服务 100%

针织设备
Knitting equipment

四针六线系列 —— 编码规则

4-needle 6-thread sewing machine series —— Coding rules



JK - 8740C - 4 60 - 02 [] H - UT - AW2S - []

① ② ③ ④ ⑤ ⑥ ⑦ ⑧ ⑨ ⑩

品牌 Brand	间隔 Interval	主型号 Main model	间隔 Interval	针数 Needle	针距 Needle distance	间隔 Interval	切刀 Cutting knife	差动 Differential	特殊规格 Special specifications	间隔 Interval	选配 Optional	间隔 Interval	吸风装置 Suction device	间隔 Interval	车缝功能 Sewing function
-------------	----------------	-------------------	----------------	--------------	-----------------------	----------------	---------------------	--------------------	--------------------------------	----------------	----------------	----------------	------------------------	----------------	-------------------------

① 品牌 Brand	
JK	杰克

② 主型号 Main model	
8740C	四针六线 Four needles six threads

③ 针数 Needle	
3	3针/3 needle
4	4针/4 needle
5	5针/5 needle

④ 针距 Needle distance	
48	宽(width) 4.8mm
52	宽(width) 5.2mm
60	宽(width) 6.0mm
64	宽(width) 6.4mm
70	宽(width) 7.0mm
80	宽(width) 8.0mm

⑤ 切刀 Cutting knife	
01	单切/Single cut
02	双切/Double cut

⑥ 差动 Differential	
	单差动/Single differential
A	双差动/Double differential

⑦ 特殊规格 Special specifications	
	普通车缝/Ordinary sewing
H	厚类车缝/Thick sewing

⑧ 选配 Optional	
D	直驱式 Direct drive type
UT	电动切线装置 Electric cutting device
UTL	气动切线装置 Pneumatic tangent device

⑨ 吸风装置 Suction device	
AW1S	气动大管: 32mm Pneumatic large pipe: 32mm
AW1L	气动小管: 25mm Pneumatic small pipe: 25mm
AW2S	电动大管: 32mm Electric large pipe: 32mm
AW2L	电动小管: 25mm Electric small pipe: 25mm

⑩ 车缝功能 Sewing function	
S	裤袜 Panty hose
DS	潜水衣 Diving suit
T1	织带(女用内衣裤) Ribbon (women's underwear)
T2	贴条 Stick strips
T3	装饰车缝贴条组, 适用7mm织带 Decorative car seam adhesive strip set, suitable for 7mm webbing
T4	上下贴条车缝, 适用6-8mm织带 Up and down stitching, suitable for 6-8mm webbing
T5	上贴条车缝组(可调式压脚), 适用7-11mm织带 Upper sticker sewing set (adjustable presser foot), suitable for 7-11mm webbing
4L10	厚料包缝过骨, 四排勾齿段差1.0mm Thick material is sewn over the bone, with a difference of 1.0mm between the four rows of hooked teeth
4L15	厚料包缝过骨, 四排勾齿段差1.5mm Thick material is sewn over the bone, with a difference of 1.5mm between the four rows of hooked teeth
4L20	厚料包缝过骨, 四排勾齿段差2.0mm Thick material is sewn through the bone, with a difference of 2.0mm between the four rows of hooked teeth

四针六线系列

功能介绍

4-needle 6-thread sewing machine series — Function introduction



扫一扫了解更多

- 8 电动剪线, 电动吸风: EK Electric thread trimmer, electric suction: EK
 气动剪线, 气动吸风: AK Pneumatic thread trimmer, pneumatic suction: AK
 电动剪线, 气动吸风: CK Electric thread trimmer, pneumatic suction: CK
 步进剪线, 电动吸风: BK Stepping thread trimming, electric suction: BK
 步进剪线, 气动吸风: DK Stepping thread trimming, pneumatic suction: DK

- 3 4 针头: 452-460常规 Needle: 452-460 regular

- 1 品牌: 杰克 Brand: Jack

- 6 差动: 单差 Differential: Single difference
 双差: A Double difference: A

- 2 型号牌: JK-8740C-460-02H-UT-AW2S

- 5-2 平板: 单切 01 Flat plate: single cut 01
 导布板: 双切 02 Fabric guide plate: double cut 02

- 9 气动吸风: AW1S Pneumatic suction: AW1S
 电动吸风: AW2S Electric suction: AW2S



5-1	7				
单切类: (01) Single cut type:	a. 单切窄槽(Z) Single cut narrow groove	b. 单切标配(B) Single cut standard	c. 单切深槽(S) Single cut deep groove	d. 单切宽刀(H) Single cut wide knife	
布料对应: Applicable fabrics:	a. 丝袜、泳装、瑜伽服 Stockings, swimwear, yoga wear	b. 针织 Knitting	c. AB面料 AB fabric	d. 厚料过硬 Too thick material	
双切类: (02) Double cut type:	e. 双切标配(B) Double cut standard	f. 双切深槽(S) Double cut deep groove	g. 双切宽刀(H) Double cut wide knife		
布料对应: Applicable fabrics:	e. 泳装 Swimsuit	f. 中厚料 Medium thickness	g. 厚料过硬 Too thick material		

- 5-3 导布器: Fabric guide:
 大: 薄料 Large: Thin
 中: 一般料 Medium: General fee
 小: 厚料 Small: thick

产品特征/Product features



下巴宽度
Chin width

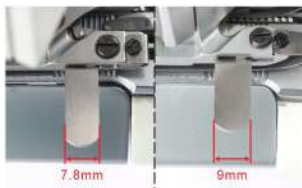

刀片宽度
Blade width



双切压脚
Double cut presser foot

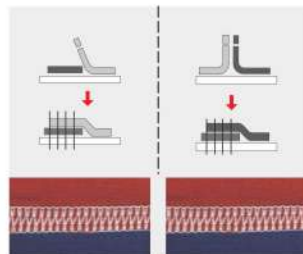

单切车缝
Single cut sewing

双切车缝
Double cut sewing

JK-8740C - 460 - 02 - UT - AW2S

①

②

③

④

⑤



扫一扫了解更多

电动式自动剪线 曲臂式四针六线

Electric automatic wire cutting

4 needles 6 threads feed-off-arm flat sewing machine

杰克牌8740四针六线 Jack 8740 4 needles and 6 threads	460针位 460 needle positions	双切标配压脚 Standard presser foot for double cutting	电动自动剪线 Electric automatic thread trimmer	电动吸风 Electric suction
①	②	③	④	⑤
	根据样品、工艺可选配针位 Optional needle position according to the sample and process.	根据布料、工艺可选配压脚 Optional presser foot according to fabric and craftsmanship	根据用户需求可选配刀组 Optional tool set according to user needs	根据用户需求可选配吸风 Optional air suction according to user needs

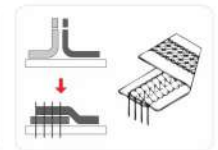

适用服装品类

Applicable clothing categories

适用于一般内衣裤二片布接缝处之拼接缝和补强、男用内裤裤底过骨拼缝、女用紧身衣裤贴条补强，拼缝，双色布料完全密合拼缝等，如：针织、泳装、瑜伽服、保暖服、潜水衣、鞋面、箱包等。

Suitable for splicing and reinforcing the seam of two pieces of general underwear, seaming at the bottom of men's underwear, strip reinforcement and patchwork for women's bodysuits, complete seaming of two-color fabrics, etc., such as: knitting, swimwear, yoga wear, thermal wear, wetsuits, shoe uppers, bags, etc.

机型 Model	针位组 Needle position group	针数 Number of needles	线数 Number of threads	修布刀 Cloth trimming knife	线迹长度 Stitch length (MM)	车缝布料 Sewing fabric	压脚高度 Presser foot height(MM)	最高转速 Max speed (S.P.M)	机针型号 Needle model	体积 Volume (CM)	重量 Weight (KG)
JK-8740C-460-02-UT-AW2S	452 460	4	6	双切 Double knife	1.6 2.5	薄 中厚 Thin, medium thick	6 8	3500	机针: UY118 假针: FLG-36211	63.8×52.8×48.5	57

JK-8740C - 460 - 02H - UTL - AW1S

①

②

③

④

⑤



扫一扫了解更多

气动式自动剪线 曲臂式四针六线

Pneumatic automatic wire cutting

4 needles 6 threads feed-off-arm flat sewing machine

杰克牌8740四针六线 Jack 8740 4 needles and 6 threads	460针位 460 needle positions	双切厚料压脚 Double cutting thick material presser foot	气动自动剪线 Pneumatic automatic thread trimmer	气动吸风 Pneumatic suction
①	②	③	④	⑤
	根据样品、工艺可选配针位 Optional needle position according to the sample and process.	根据布料、工艺可选配压脚 Optional presser foot according to fabric and craftsmanship	根据用户需求可选配刀组 Optional tool set according to user needs	根据用户需求可选配吸风 Optional air suction according to user needs

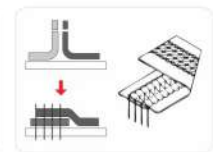

适用服装品类

Applicable clothing categories

适用于一般内衣裤二片布接缝处之拼接缝和补强、男用内裤裤底过骨拼缝、女用紧身衣裤贴条补强，拼缝，双色布料完全密合拼缝等，如：针织、泳装、瑜伽服、保暖服、潜水衣、鞋面、箱包等。

Suitable for splicing and reinforcing the seam of two pieces of general underwear, seaming at the bottom of men's underwear, strip reinforcement and patchwork for women's bodysuits, complete seaming of two-color fabrics, etc., such as: knitting, swimwear, yoga wear, thermal wear, wetsuits, shoe uppers, bags, etc.

机型 Model	针位组 Needle position group	针数 Number of needles	线数 Number of threads	修布刀 Cloth trimming knife	线迹长度 Stitch length (MM)	车缝布料 Sewing fabric	压脚高度 Presser foot height(MM)	最高转速 Max speed (S.P.M)	机针型号 Needle model	体积 Volume (CM)	重量 Weight (KG)
JK-8740C-460-02H-UTL-AW1S	452 460	4	6	双切宽刀 Double wide knife	1.6 2.5	中厚 厚料 Medium thick, thick	6 8	3500	机针: UY118 假针: FLG-36211	63.8×52.8×48.5	57

JK-8740C - 452 - 02 - D - AW2S

①

②

③

④

⑤



扫一扫了解更多

电动式 曲臂式四针六线

Electric type

4 needles 6 threads feed-off-arm flat sewing machine

杰克牌8740四针六线 Jack 8740 4 needles and 6 threads	452针位 452 needle positions	双切标配压脚 Standard presser foot for double cutting	电脑直驱 Computer direct drive	电动吸风 Electric suction
①	②	③	④	⑤
	根据样品、工艺可选配针位 Optional needle position according to the sample and process.	根据布料、工艺可选配压脚 Optional presser foot according to fabric and craftsmanship	根据用户需求可选配配置 Optional configurations according to user needs	根据用户需求可选配吸风 Optional air suction according to user needs

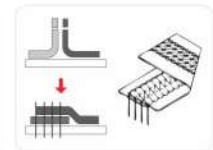

适用服装品类

Applicable clothing categories

适用于一般内衣裤二片布接缝处之拼接缝和补强、男用内裤裤底过骨拼缝、女用紧身衣裤贴条补强，拼缝，双色布料完全密合拼缝等，如：针织、泳装、瑜伽服、保暖服、潜水衣、鞋面、箱包等。

Suitable for splicing and reinforcing the seam of two pieces of general underwear, seaming at the bottom of men's underwear, strip reinforcement and patchwork for women's bodysuits, complete seaming of two-color fabrics, etc., such as: knitting, swimwear, yoga wear, thermal wear, wetsuits, shoe uppers, bags, etc.

机型 Model	针位组 Needle position group	针数 Number of needles	线数 Number of threads	修布刀 Cloth trimming knife	线迹长度 Stitch length (MM)	车缝布料 Sewing fabric	压脚高度 Presser foot height(MM)	最高转速 Max speed (S.P.M)	机针型号 Needle model	体积 Volume (CM)	重量 Weight (KG)
JK-8740C-452-02-D-AW2S	452 460	4	6	双切 Double knife	1.6 2.5	薄 中厚 Thin, medium thick	6 8	3500	机针: UY118 假针: FLG-36211	63.8×52.8×48.5	57

JK-8740C - 452 - 01 - D - AW1S

①

②

③

④

⑤



扫一扫了解更多

气动式 曲臂式四针六线

Pneumatic type

4 needles 6 threads feed-off-arm flat sewing machine

杰克牌8740四针六线 Jack 8740 4 needles and 6 threads	452针位 452 needle positions	单切标配压脚 Standard presser foot for single cutting	电脑直驱 Computer direct drive	气动吸风 Pneumatic suction
①	②	③	④	⑤
	根据样品、工艺可选配针位 Optional needle position according to the sample and process.	根据布料、工艺可选配压脚 Optional presser foot according to fabric and craftsmanship	根据用户需求可选配配置 Optional configurations according to user needs	根据用户需求可选配吸风 Optional air suction according to user needs

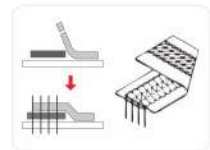

适用服装品类

Applicable clothing categories

适用于一般内衣裤二片布接缝处之拼接缝和补强、男用内裤裤底过骨拼缝、女用紧身衣裤贴条补强，拼缝，双色布料完全密合拼缝等，如：针织、泳装、瑜伽服、保暖服、潜水衣、鞋面、箱包等。

Suitable for splicing and reinforcing the seam of two pieces of general underwear, seaming at the bottom of men's underwear, strip reinforcement and patchwork for women's bodysuits, complete seaming of two-color fabrics, etc., such as: knitting, swimwear, yoga wear, thermal wear, wetsuits, shoe uppers, bags, etc.

机型 Model	针位组 Needle position group	针数 Number of needles	线数 Number of threads	修布刀 Cloth trimming knife	线迹长度 Stitch length (MM)	车缝布料 Sewing fabric	压脚高度 Presser foot height(MM)	最高转速 Max speed (S.P.M)	机针型号 Needle model	体积 Volume (CM)	重量 Weight (KG)
JK-8740C-452-01-D-AW1S	452 460	4	6	单切 Single knife	1.6 2.5	薄 中厚 Thin, medium thick	6 8	3500	机针: UY118 假针: FLG-36211	63.8×52.8×48.5	57

JK-8740C - 460 - 02 - A - UT - AW2S

①

②

③

④

⑤



扫一扫了解更多

双差动电动式自动剪线 曲臂式四针六线

Double differential electric automatic wire cutting

4 needles 6 threads feed-off-arm flat sewing machine

杰克牌8740四针六线 Jack 8740 4 needles and 6 threads	460针位 460 needle positions	双切标配压脚-双差动 Presser foot for 2 cutting - 2 differential	电动自动剪线 Electric automatic thread trimmer	电动吸风 Electric suction
①	②	③	④	⑤
	根据样品、工艺可选配针位 Optional needle position according to the sample and process.	根据布料、工艺可选配压脚和差动方式 Optional presser foot and differential mode according to fabric and craftsmanship	根据用户需求可选配刀组 Optional tool set according to user needs	根据用户需求可选配吸风 Optional air suction according to user needs



后置增加双差动
Add double differential at the rear



适用服装品类

Applicable clothing categories

适用于一般内衣裤二片布接缝处之拼接缝和补强、男用内裤裤底过骨拼缝、女用紧身衣裤贴条补强，拼缝，双色布料完全密合拼缝等，如：针织、泳装、瑜伽服、保暖服、潜水衣、鞋面、箱包等。
Suitable for splicing and reinforcing the seam of two pieces of general underwear, seaming at the bottom of men's underwear, strip reinforcement and patchwork for women's bodysuits, complete seaming of two-color fabrics, etc., such as: knitting, swimwear, yoga wear, thermal wear, wetsuits, shoe uppers, bags, etc.

机型 Model	针位组 Needle position group	针数 Number of needles	线数 Number of threads	修布刀 Cloth trimming knife	线迹长度 Stitch length (MM)	车缝布料 Sewing fabric	压脚高度 Presser foot height(MM)	最高转速 Max speed (S.P.M)	机针型号 Needle model	体积 Volume (CM)	重量 Weight (KG)
JK-8740C-460-02-A-UT-AW2S	452 460	4	6	双切 Double knife	1.6 2.5	薄 中厚 Thin, medium thick	6 8	3500	机针: UY118 假针: FLG-36211	63.8×52.8×48.5	57

筒式绷缝系列 —— 编码规则

Tube type interlock sewing machine series — Coding rules



JK - 1500 E - 1 56 - M - UT2

① ② ③ ④ ⑤ ⑥ ⑦

品牌 Brand	间隔 Interval	主型号 Main model	机型款式 Type	间隔 Interval	针数 Needle	针位 Needle position	间隔 Interval	操作空间 Operating space	间隔 Interval	直驱 Special specifications
-------------	----------------	-------------------	--------------	----------------	--------------	-----------------------	----------------	-------------------------	----------------	------------------------------

① 品牌 Brand		④ 针数 Needle		⑦ 直驱 Special specifications							
JK	杰克	1	三针五线 3 needles and 5 threads		皮带轮 Pulley						
② 主型号 Main model		4	四针六线 4 needles and 6 threads	D	直驱电机 Direct drive motor						
1500	普通缝 Ordinary seam	⑤ 针位 Needle position		DT	普通直驱加电动抬压脚 Ordinary direct drive plus electric presser foot lift						
1502	双针双链贴条缝 Double needle double chain taped seam	56	5.6mm	UT	电动自动剪线 Electric automatic thread trimmer						
③ 机型款式 Type		64	6.4mm	UT2	自动剪线加拨线器 Automatic thread trimmer and thread dialer						
C	常规款 Regular type	60	6.0mm	UT3	伺服直驱, 电动下切线刀、上网线切刀 Servo direct drive, electric lower thread cutter, upper thread cutter						
E	步进款 Step type	⑥ 操作空间 Operating space		UTL	气动自动剪线 Pneumatic automatic thread trimming						
		M	标准款 Standard type								
		L	加长款 Extra long type								

筒式绷缝系列 —— 功能介绍

Tube type interlock sewing machine series — Function introduction



扫一扫了解更多

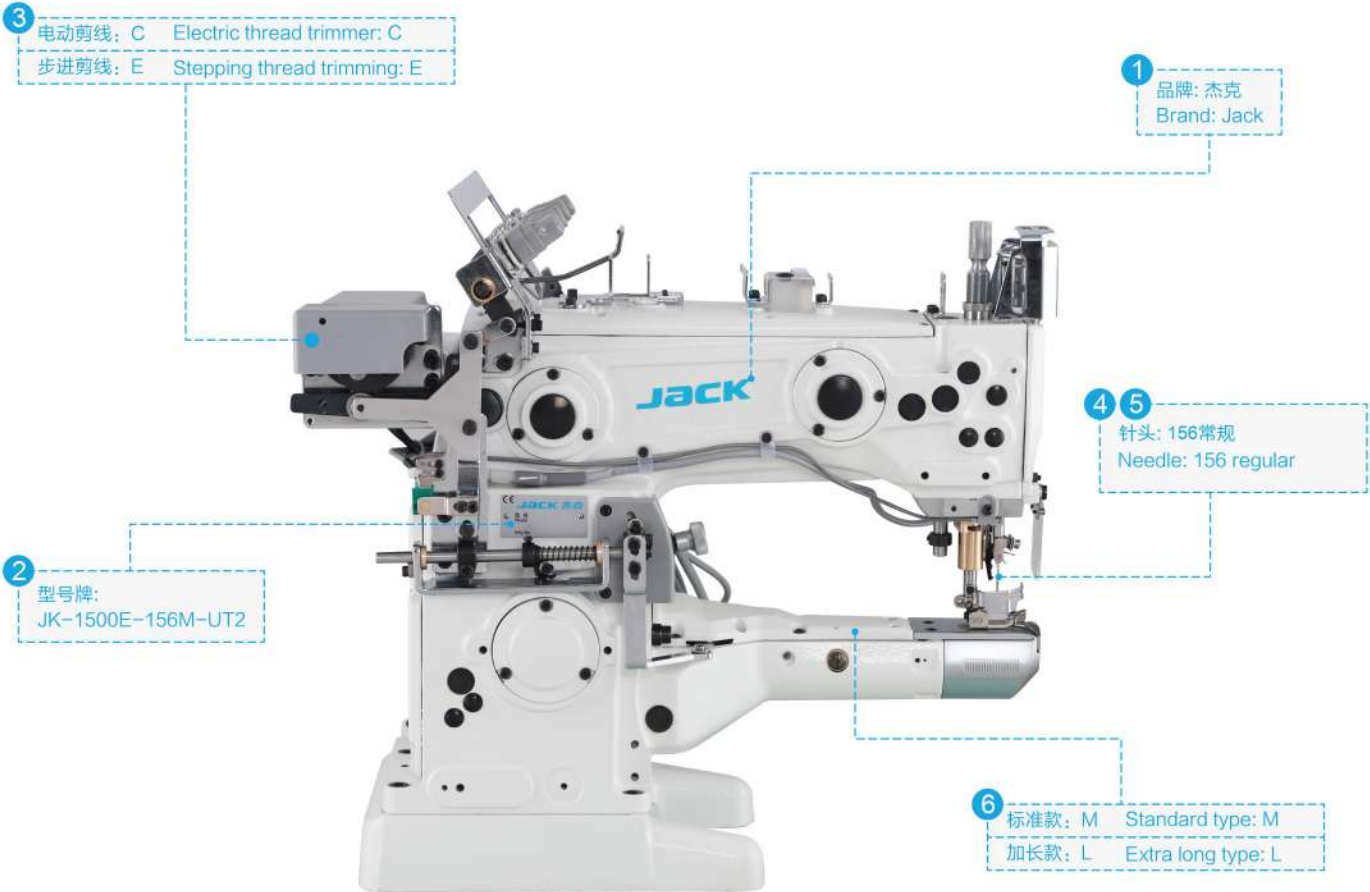

产品特征/Product features

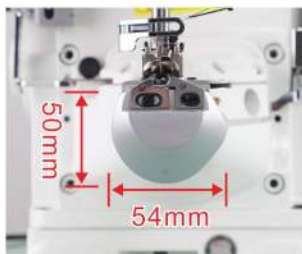

一体式针板
Integrated needle plate



步进电机, 操作方便
Stepper motor, easy to operate



内置铜套
Horn Cloth Inducer



直驱节能电机
Direct drive energy-saving motor

JK-1500 E - 156 M - UT2

①

②

③

④

⑤



扫一扫了解更多

步进一体自动剪线 直筒式绷缝机

Step-by-step automatic thread trimming

transverse tube type interlock sewing machine

杰克牌1500筒式绷缝 Jack 1500 Tube type interlock	步进自动剪线 Step automatic thread trimming	156针位 156 needle positions	标准臂长 Standard arm length	自动剪线加拨线器 Auto thread trimmer and thread dialer
①	②	③	④	⑤
	可选常规款 Optional regular type	根据样品、工艺可选配针位 Optional needle position according to the sample and process.	可选加长款 Optional extension	根据用户需求可选配配置 Optional configurations according to user needs



适用服装品类

Applicable clothing categories

适用于一般内衣裤二片布接缝处之拼接缝和补强、男用内裤裤底过骨拼缝，女用紧身衣裤贴条补强，拼缝，双色布料完全密合拼缝等，如：针织、泳装、瑜伽服、保暖服等。

Suitable for splicing and reinforcing the seam of two pieces of general underwear, seaming at the bottom of men's underwear, strip reinforcement and patchwork for women's bodysuits, complete seaming of two-color fabrics, etc., such as: knitting, swimwear, yoga wear, thermal wear, etc.

机型 Model	针位组 Needle position group	针数 Number of needles	线数 Number of threads	下巴长度 Chin length (MM)	线迹长度 Stitch length (MM)	车缝布料 Sewing fabric	压脚高度 Presser foot height(MM)	最高转速 Max speed (S.P.M)	机针型号 Needle model	体积 Volume (CM)	重量 Weight (KG)
JK-1500E-156M-UT2	356	3	5	280	5	薄 中厚 厚料 Thin, medium thick, thick material	10	4200	UV128GAS (薄、中厚料) TV×7 (厚料过梗)	62.5×53.5×58.5	58

JK-1500 E - 156 L - UT2

① ② ③ ④ ⑤



扫一扫了解更多

步进一体自动剪线长臂 直筒式绷缝机

Step-by-step automatic thread trimming long arm transverse tube type interlock sewing machine

杰克牌1500筒式绷缝 Jack 1500 Tube type interlock	步进自动剪线 Step automatic thread trimming	156针位 156 needle positions	加长臂长 Extend arm length	自动剪线加拨线器 Auto thread trimmer and thread dialer
①	②	③	④	⑤
	可选常规款 Optional regular type	根据样品、工艺可选配针位 Optional needle position according to the sample and process.	可选标准长 Optional standard length	根据用户需求可选配配置 Optional configurations according to user needs

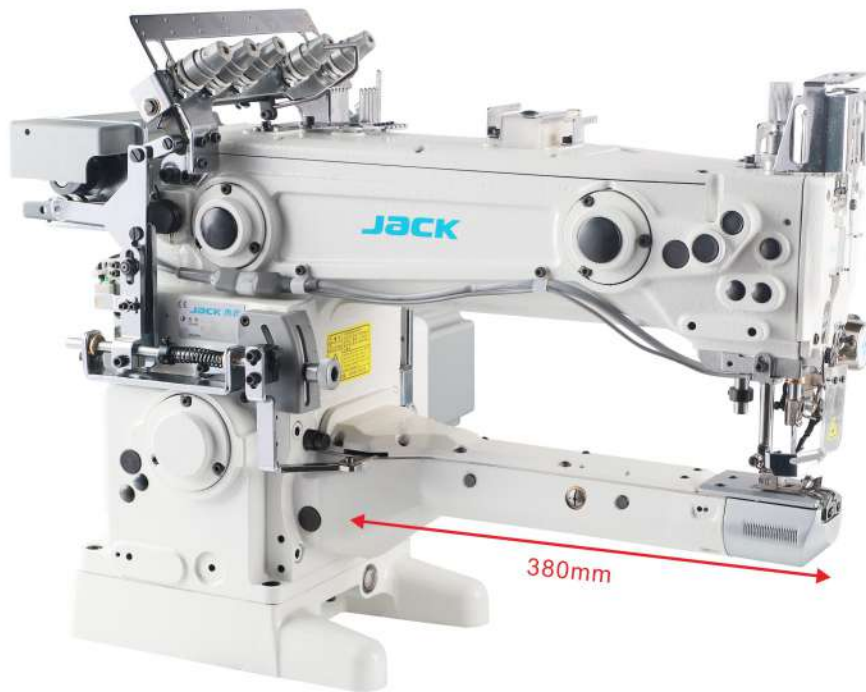

适用服装品类

Applicable clothing categories

适用于一般内衣裤二片布接缝处之拼接缝和补强、男用内裤裤底过骨拼缝，女用紧身衣裤贴条补强，拼缝，双色布料完全密合拼缝等，如：针织、泳装、瑜伽服、保暖服等。

Suitable for splicing and reinforcing the seam of two pieces of general underwear, seaming at the bottom of men's underwear, strip reinforcement and patchwork for women's bodysuits, complete seaming of two-color fabrics, etc., such as: knitting, swimwear, yoga wear, thermal wear, etc.

机型 Model	针位组 Needle position group	针数 Number of needles	线数 Number of threads	下巴长度 Chin length (MM)	线迹长度 Stitch length (MM)	车缝布料 Sewing fabric	压脚高度 Presser foot height(MM)	最高转速 Max speed (S.P.M)	机针型号 Needle model	体积 Volume (CM)	重量 Weight (KG)
JK-1500E-156L-UT2	356	3	5	380	5	薄 中厚 厚料 Thin, medium thick, thick material	10	4200	UV128GAS (薄、中厚料) TV×7 (厚料过梗)	68.5×51×65	66

JK-1500 **E - 156** **M - DT**

① ② ③ ④ ⑤



扫一扫了解更多

步进一体 直筒式绷缝机

Step-by-step

transverse tube type interlock sewing machine

杰克牌1500筒式绷缝 Jack 1500 Tube type interlock	步进自动剪线 Step automatic thread trimming	156针位 156 needle positions	标准臂长 Standard arm length	普通直驱加电动抬压脚 Direct drive + electric presser foot lift
①	②	③	④	⑤
	可选常规款 Optional regular type	根据样品、工艺可选配针位 Optional needle position according to the sample and process.	可选加长款 Optional extension	根据用户需求可选配配置 Optional configurations according to user needs



适用服装品类

Applicable clothing categories

适用于一般内衣裤二片布接缝处之拼接缝和补强、男用内裤裤底过骨拼缝，女用紧身衣裤贴条补强，拼缝，双色布料完全密合拼缝等，如：针织、泳装、瑜伽服、保暖服等。

Suitable for splicing and reinforcing the seam of two pieces of general underwear, seaming at the bottom of men's underwear, strip reinforcement and patchwork for women's bodysuits, complete seaming of two-color fabrics, etc., such as: knitting, swimwear, yoga wear, thermal wear, etc.

机型 Model	针位组 Needle position group	针数 Number of needles	线数 Number of threads	下巴长度 Chin length (MM)	线迹长度 Stitch length (MM)	车缝布料 Sewing fabric	压脚高度 Presser foot height(MM)	最高转速 Max speed (S.P.M)	机针型号 Needle model	体积 Volume (CM)	重量 Weight (KG)
JK-1500E-156M-DT	356	3	5	280	5	薄 中厚 厚料 Thin, medium thick, thick material	10	4200	UV128GAS (薄、中厚料) TV×7 (厚料过梗)	62.5×53.5×58.5	58

JK-1500 E - 156 L - DT

①

②

③

④

⑤



扫一扫了解更多

步进一体长臂 直筒式绷缝机

Step-by-step long arm

transverse tube type interlock sewing machine

杰克牌1500筒式绷缝 Jack 1500 Tube type interlock	步进自动剪线 Step automatic thread trimming	156针位 156 needle positions	加长臂长 Extend arm length	普通直驱加电动抬压脚 Direct drive + electric presser foot lift
①	②	③	④	⑤
	可选常规款 Optional regular type	根据样品、工艺可选配针位 Optional needle position according to the sample and process.	可选标准长 Optional standard length	根据用户需求可选配配置 Optional configurations according to user needs

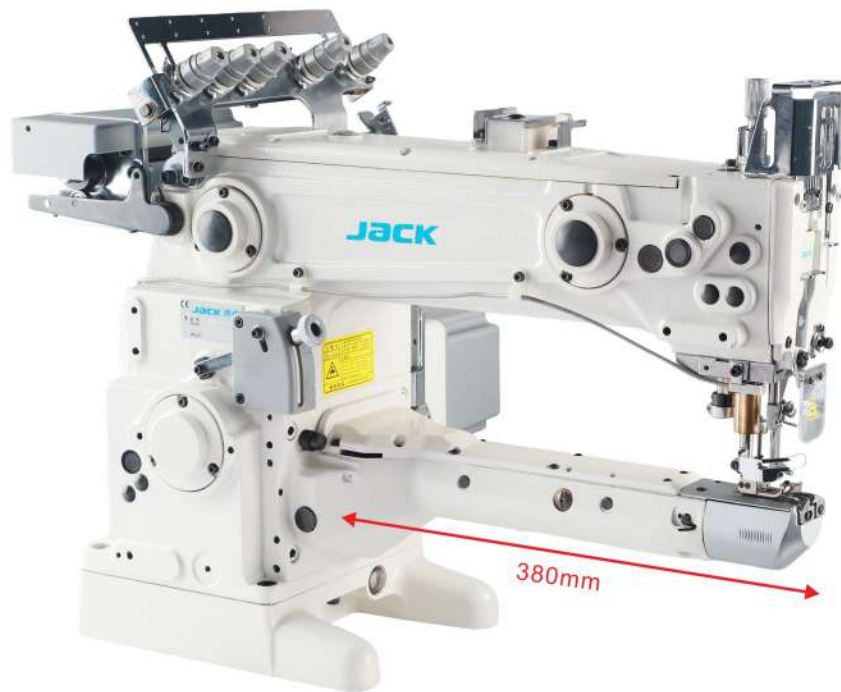

适用服装品类

Applicable clothing categories

适用于一般内衣裤二片布接缝处之拼接缝和补强、男用内裤裤底过骨拼缝，女用紧身衣裤贴条补强，拼缝，双色布料完全密合拼缝等，如：针织、泳装、瑜伽服、保暖服等。

Suitable for splicing and reinforcing the seam of two pieces of general underwear, seaming at the bottom of men's underwear, strip reinforcement and patchwork for women's bodysuits, complete seaming of two-color fabrics, etc., such as: knitting, swimwear, yoga wear, thermal wear, etc.

机型 Model	针位组 Needle position group	针数 Number of needles	线数 Number of threads	下巴长度 Chin length (MM)	线迹长度 Stitch length (MM)	车缝布料 Sewing fabric	压脚高度 Presser foot height(MM)	最高转速 Max speed (S.P.M)	机针型号 Needle model	体积 Volume (CM)	重量 Weight (KG)
JK-1500E-156L-DT	356	3	5	380	5	薄 中厚 厚料 Thin, medium thick, thick material	10	4200	UV128GAS (薄、中厚料) TV×7 (厚料过梗)	68.5×51×65	66

JK-1500 E - 464 M - UT

①

②

③

④

⑤



扫一扫了解更多

步进一体自动剪线 直筒式绷缝机

Step-by-step automatic thread trimming

transverse tube type interlock sewing machine

杰克牌1500筒式绷缝 Jack 1500 Tube type interlock	步进自动剪线 Step automatic thread trimming	464针位 464 needle positions	标准臂长 Standard arm length	电动自动剪线 Electric automatic thread trimmer
①	②	③	④	⑤
	可选常规款 Optional regular type	根据样品、工艺可选配针位 Optional needle position according to the sample and process.	可选加长款 Optional extension	根据用户需求可选配配置 Optional configurations according to user needs



适用服装品类

Applicable clothing categories

适用于一般内衣裤二片布接缝处之拼接缝和补强、男用内裤裤底过骨拼缝，女用紧身衣裤贴条补强，拼缝，双色布料完全密合拼缝等，如：针织、泳装、瑜伽服、保暖服等。

Suitable for splicing and reinforcing the seam of two pieces of general underwear, seaming at the bottom of men's underwear, strip reinforcement and patchwork for women's bodysuits, complete seaming of two-color fabrics, etc., such as: knitting, swimwear, yoga wear, thermal wear, etc.

机型 Model	针位组 Needle position group	针数 Number of needles	线数 Number of threads	下巴长度 Chin length (MM)	线迹长度 Stitch length (MM)	车缝布料 Sewing fabric	压脚高度 Presser foot height(MM)	最高转速 Max speed (S.P.M)	机针型号 Needle model	体积 Volume (CM)	重量 Weight (KG)
JK-1500E-464M-UT	464	4	6	280	5	薄 中厚 厚料 Thin, medium thick, thick material	10	4200	UV128GAS (薄、中厚料) TV×7 (厚料过梗)	62.5×53.5×58.5	58

JK-1500 E - 464 L - UT

①

②

③

④

⑤



扫一扫了解更多

步进一体自动剪线长臂 直筒式绷缝机

Step-by-step automatic thread trimming long arm transverse tube type interlock sewing machine

杰克牌1500筒式绷缝 Jack 1500 Tube type interlock	步进自动剪线 Step automatic thread trimming	464针位 464 needle positions	加长臂长 Extend arm length	电动自动剪线 Electric automatic thread trimmer
①	②	③	④	⑤
	可选常规款 Optional regular type	根据样品、工艺可选配针位 Optional needle position according to the sample and process.	可选标准长 Optional standard length	根据用户需求可选配配置 Optional configurations according to user needs

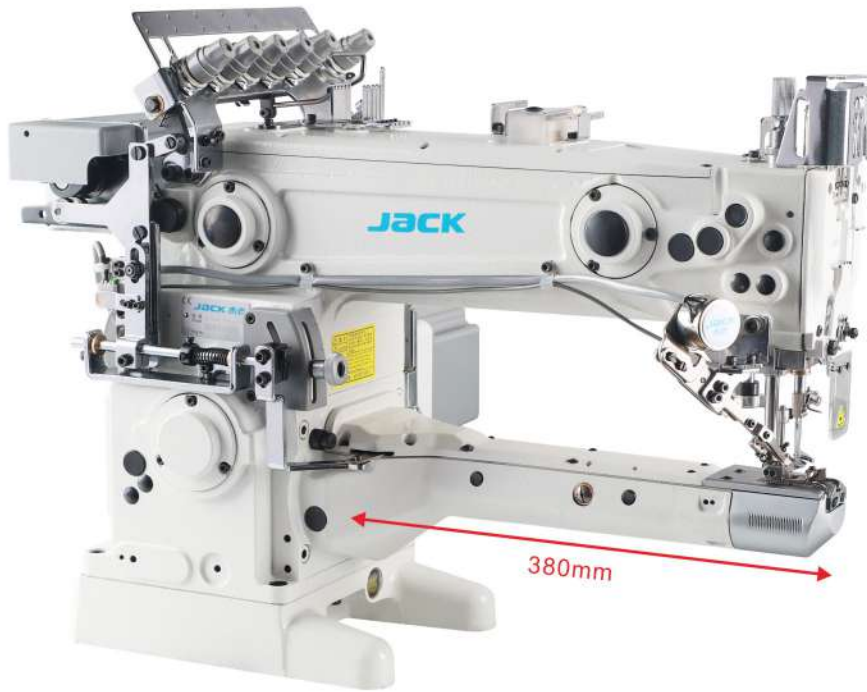

适用服装品类

Applicable clothing categories

适用于一般内衣裤二片布接缝处之拼接缝和补强、男用内裤裤底过骨拼缝，女用紧身衣裤贴条补强，拼缝，双色布料完全密合拼缝等，如：针织、泳装、瑜伽服、保暖服等。

Suitable for splicing and reinforcing the seam of two pieces of general underwear, seaming at the bottom of men's underwear, strip reinforcement and patchwork for women's bodysuits, complete seaming of two-color fabrics, etc., such as: knitting, swimwear, yoga wear, thermal wear, etc.

机型 Model	针位组 Needle position group	针数 Number of needles	线数 Number of threads	下巴长度 Chin length (MM)	线迹长度 Stitch length (MM)	车缝布料 Sewing fabric	压脚高度 Presser foot height(MM)	最高转速 Max speed (S.P.M)	机针型号 Needle model	体积 Volume (CM)	重量 Weight (KG)
JK-1500E-464L-UT	464	4	6	380	5	薄 中厚 厚料 Thin, medium thick, thick material	10	4200	UV128GAS (薄、中厚料) TV×7 (厚料过梗)	68.5×51×65	66

JK-1502 E - 264 M - DT

①

②

③

④

⑤



扫一扫了解更多

步进一体上贴条 直筒式绷缝机

Step-by-step attach a sticker

transverse tube type interlock sewing machine

杰克牌1500筒式绷缝 Jack 1500 Tube type interlock	步进自动剪线 Step automatic thread trimming	264针位 264 needle positions	标准臂长 Standard arm length	普通直驱加电动抬压脚 Direct drive + electric presser foot lift
①	②	③	④	⑤
	可选常规款 Optional regular type	根据样品、工艺可选配针位 Optional needle position according to the sample and process.	可选加长款 Optional extension	根据用户需求可选配配置 Optional configurations according to user needs



适用服装品类

Applicable clothing categories

适用于一般内衣裤二片布接缝处之拼接缝和补强、男用内裤裤底过骨拼缝, 女用紧身衣裤贴条补强, 拼缝, 双色布料完全密合拼缝等, 如: 针织、泳装、瑜伽服、保暖服等。

Suitable for splicing and reinforcing the seam of two pieces of general underwear, seaming at the bottom of men's underwear, strip reinforcement and patchwork for women's bodysuits, complete seaming of two-color fabrics, etc., such as: knitting, swimwear, yoga wear, thermal wear, etc.

机型 Model	针位组 Needle position group	针数 Number of needles	线数 Number of threads	下巴长度 Chin length (MM)	线迹长度 Stitch length (MM)	车缝布料 Sewing fabric	压脚高度 Presser foot height(MM)	最高转速 Max speed (S.P.M)	机针型号 Needle model	体积 Volume (CM)	重量 Weight (KG)
JK-1502E-264M-DT	264	2	4	280	5	薄 中厚 厚料 Thin, medium thick, thick material	10	4200	UV128GAS (薄、中厚料) TV×7 (厚料过梗)	62.5×53.5×58.5	58

JK-1502 E - 264 M - UT

①

②

③

④

⑤



扫一扫了解更多

步进一体自动剪线上贴条 直筒式绷缝机

Step-by-step automatic thread trimming attach a sticker
transverse tube type interlock sewing machine

杰克牌1500筒式绷缝 Jack 1500 Tube type interlock	步进自动剪线 Step automatic thread trimming	264针位 264 needle positions	标准臂长 Standard arm length	电动自动剪线 Electric automatic thread trimmer
①	②	③	④	⑤
	可选常规款 Optional regular type	根据样品、工艺可选配针位 Optional needle position according to the sample and process.	可选加长款 Optional extension	根据用户需求可选配配置 Optional configurations according to user needs



适用服装品类

Applicable clothing categories

适用于一般内衣裤二片布接缝处之拼接缝和补强、男用内裤裤底过骨拼缝，女用紧身衣裤贴条补强，拼缝，双色布料完全密合拼缝等，如：针织、泳装、瑜伽服、保暖服等。

Suitable for splicing and reinforcing the seam of two pieces of general underwear, seaming at the bottom of men's underwear, strip reinforcement and patchwork for women's bodysuits, complete seaming of two-color fabrics, etc., such as: knitting, swimwear, yoga wear, thermal wear, etc.

机型 Model	针位组 Needle position group	针数 Number of needles	线数 Number of threads	下巴长度 Chin length (MM)	线迹长度 Stitch length (MM)	车缝布料 Sewing fabric	压脚高度 Presser foot height(MM)	最高转速 Max speed (S.P.M)	机针型号 Needle model	体积 Volume (CM)	重量 Weight (KG)
JK-1502E-264M-UT	264	2	4	280	5	薄 中厚 厚料 Thin, medium thick, thick material	10	4200	UV128GAS (薄、中厚料) TV×7 (厚料过梗)	62.5×53.5×58.5	58

JK-1502 E - 264 L - DT

①

②

③

④

⑤



扫一扫了解更多

步进一体长臂上贴条 直筒式绷缝机

Step-by-step long arm attach a sticker

transverse tube type interlock sewing machine

杰克牌1500筒式绷缝 Jack 1500 Tube type interlock	步进自动剪线 Step automatic thread trimming	264针位 264 needle positions	加长臂长 Extend arm length	普通直驱加电动抬压脚 Direct drive + electric presser foot lift
①	②	③	④	⑤
	可选常规款 Optional regular type	根据样品、工艺可选配针位 Optional needle position according to the sample and process.	可选标准长 Optional standard length	根据用户需求可选配配置 Optional configurations according to user needs



适用服装品类

Applicable clothing categories

适用于一般内衣裤二片布接缝处之拼接缝和补强、男用内裤裤底过骨拼缝, 女用紧身衣裤贴条补强, 拼缝, 双色布料完全密合拼缝等, 如: 针织、泳装、瑜伽服、保暖服等。

Suitable for splicing and reinforcing the seam of two pieces of general underwear, seaming at the bottom of men's underwear, strip reinforcement and patchwork for women's bodysuits, complete seaming of two-color fabrics, etc., such as: knitting, swimwear, yoga wear, thermal wear, etc.

机型 Model	针位组 Needle position group	针数 Number of needles	线数 Number of threads	下巴长度 Chin length (MM)	线迹长度 Stitch length (MM)	车缝布料 Sewing fabric	压脚高度 Presser foot height(MM)	最高转速 Max speed (S.P.M)	机针型号 Needle model	体积 Volume (CM)	重量 Weight (KG)
JK-1502E-264L-DT	264	2	4	380	5	薄 中厚 厚料 Thin, medium thick, thick material	10	4200	UV128GAS (薄、中厚料) TV×7 (厚料过梗)	68.5×51×65	66

JK-1502 E - 264 M - DT

①

②

③

④

⑤



扫一扫了解更多

步进一体下贴条 直筒式绷缝机

Step-by-step bottom sticker

transverse tube type interlock sewing machine

杰克牌1500筒式绷缝 Jack 1500 Tube type interlock	步进自动剪线 Step automatic thread trimming	264针位 264 needle positions	标准臂长 Standard arm length	普通直驱加电动抬压脚 Direct drive + electric presser foot lift
①	②	③	④	⑤
	可选常规款 Optional regular type	根据样品、工艺可选配针位 Optional needle position according to the sample and process.	可选加长款 Optional extension	根据用户需求可选配配置 Optional configurations according to user needs



适用服装品类

Applicable clothing categories

适用于一般内衣裤二片布接缝处之拼接缝和补强、男用内裤裤底过骨拼缝、女用紧身衣裤贴条补强，拼缝，双色布料完全密合拼缝等，如：针织、泳装、瑜伽服、保暖服等。

Suitable for splicing and reinforcing the seam of two pieces of general underwear, seaming at the bottom of men's underwear, strip reinforcement and patchwork for women's bodysuits, complete seaming of two-color fabrics, etc., such as: knitting, swimwear, yoga wear, thermal wear, etc.

机型 Model	针位组 Needle position group	针数 Number of needles	线数 Number of threads	下巴长度 Chin length (MM)	线迹长度 Stitch length (MM)	车缝布料 Sewing fabric	压脚高度 Presser foot height(MM)	最高转速 Max speed (S.P.M)	机针型号 Needle model	体积 Volume (CM)	重量 Weight (KG)
JK-1502E-264M-DT	264	2	4	280	5	薄 中厚 厚料 Thin, medium thick, thick material	10	4200	UV128GAS (薄、中厚料) TV×7 (厚料过梗)	62.5×53.5×58.5	58

JK-1502 **E - 264** **L - DT**

① ② ③ ④ ⑤



扫一扫了解更多

步进一体长臂下贴条 直筒式绷缝机

Step-by-step long arm bottom sticker
transverse tube type interlock sewing machine

杰克牌1500筒式绷缝 Jack 1500 Tube type interlock	步进自动剪线 Step automatic thread trimming	264针位 264 needle positions	加长臂长 Extend arm length	普通直驱加电动抬压脚 Direct drive + electric presser foot lift
①	②	③	④	⑤
	可选常规款 Optional regular type	根据样品、工艺可选配针位 Optional needle position according to the sample and process.	可选标准长 Optional standard length	根据用户需求可选配配置 Optional configurations according to user needs



适用服装品类

Applicable clothing categories

适用于一般内衣裤二片布接缝处之拼接缝和补强、男用内裤裤底过骨拼缝，女用紧身衣裤贴条补强，拼缝，双色布料完全密合拼缝等，如：针织、泳装、瑜伽服、保暖服等。

Suitable for splicing and reinforcing the seam of two pieces of general underwear, seaming at the bottom of men's underwear, strip reinforcement and patchwork for women's bodysuits, complete seaming of two-color fabrics, etc., such as: knitting, swimwear, yoga wear, thermal wear, etc.

机型 Model	针位组 Needle position group	针数 Number of needles	线数 Number of threads	下巴长度 Chin length (MM)	线迹长度 Stitch length (MM)	车缝布料 Sewing fabric	压脚高度 Presser foot height(MM)	最高转速 Max speed (S.P.M)	机针型号 Needle model	体积 Volume (CM)	重量 Weight (KG)
JK-1502E-264L-DT	264	2	4	380	5	薄 中厚 厚料 Thin, medium thick, thick material	10	4200	UV128GAS (薄、中厚料) TV×7 (厚料过梗)	68.5×51×65	66

小方头绷缝系列 — 编码规则

Small cylinder bed interlock machine series — Coding rules



JK - 8787E - 01G B - 3 56 - UT2 -

品牌 Brand	间隔 Interval	主型号 Main model	间隔 Interval	特征1 Feature 1	特征2 Feature 2	间隔 Interval	针数 Needle	针距 Needle distance	间隔 Interval	选配 Optional	间隔 Interval	装置 Device
-------------	----------------	-------------------	----------------	------------------	------------------	----------------	--------------	-----------------------	----------------	----------------	----------------	--------------

① 品牌 Brand	杰克
JK	杰克

② 主型号 Main model	普通缝 Ordinary seam
8787	普通缝 Ordinary seam
8787E	步进款 Stepping type

③ 特征1 Feature 1	普通缝 Ordinary seam
01G	普通缝 Ordinary seam
02B	包边缝 Edge covering sewing
35A	带左切刀 With left cutting blade
33A	带右切刀 With right cutting blade

④ 特征2 Feature 2	针板小舌头后面长度为标准的 The length behind the small tongue of the needle board is standard
B	针板小舌头后面长度为标准的 The length behind the small tongue of the needle board is standard
C	针板小舌头后面长度为长的 The length behind the small tongue of the needle board is long

⑤ 针数 Needle	2针/2 needle
2	2针/2 needle
3	3针/3 needle
4	4针/4 needle

⑥ 针距 Needle distance	宽(width) 4.0mm
40	宽(width) 4.0mm
48	宽(width) 4.8mm
56	宽(width) 5.6mm
60	宽(width) 6.0mm
64	宽(width) 6.4mm

⑦ 辅助装置 Auxiliary device	直驱式 Direct drive type
D	直驱式 Direct drive type
UT	上剪线+下剪线+拨线(电动式) Up cutting+down cutting+wire pulling (electric type)
UT2	下剪线+拨线器(电动式) Wire cutting+wire puller (electric type)
UT3	下剪线+上剪线(电动式) Lower cutting line+upper cutting line (electric type)
UTL	上剪线+下剪线+拨线(气动式) Upper wire cutting+lower wire cutting+wire pulling (pneumatic)

⑧ 辅助装置 Auxiliary device	后拖轮装置(齿轮) Rear towing device (gear)
PL	后拖轮装置(齿轮) Rear towing device (gear)
PR	后拖轮装置(平轮) Rear towing device (flat wheel)
F	上裤腰装置 Upper waistband device
AW1S	气动吸风装置(左、右切刀专用) Pneumatic suction device (dedicated for left and right cutting blades)
AW2S	电动吸风装置(左、右切刀专用) Electric suction device (dedicated for left and right cutting blades)

小方头绷缝系列 — 功能介绍

Small cylinder bed interlock machine series — Function introduction



扫一扫了解更多

5 6 针头: 356常规 Needle: 356 regular

1 品牌: 杰克 Brand: Jack

2 型号牌: JK-8787E-01GB-356-UT2

7 8 UT2: 下剪线+拨线器(电动式) Wire cutting+wire puller (electric type)



产品特征/Product features



"密封式"侧盖
Sealed side cover



短横筒设计
Short horizontal tube design



步进电机, 操作方便
Stepper motor, easy to operate



微调式底线切刀组
Fine tuned bottom line cutter set

JK-8787 E - 01GB - 356 - UT2

①

②

③

④

⑤



扫一扫了解更多

步进一体自动剪线 小方头绷缝机

Step by step automatic thread cutting

Small cylinder bed interlock sewing machine

杰克牌8787小方头绷缝 Jack 8787 cylinder bed interlock	步进自动剪线 Step automatic thread trimming	普通缝 356 needle positions	356针位 356 needle positions	下剪线+拨线器(电动式) Wire cutting+wire puller (electric type)
①	②	③	④	⑤
	可选常规款 Optional regular type	根据用户需求可选配刀组 Optional tool set according to user needs	根据样品、工艺可选配针位 Optional needle position according to the sample and process.	根据用户需求可选配配置 Optional configurations according to user needs



适用服装品类

Applicable clothing categories

适用于一般内衣裤二片布接缝处之拼接缝和补强、男用内裤裤底过骨拼缝，女用紧身衣裤贴条补强，拼缝，双色布料完全密合拼缝等，如：针织、泳装、瑜伽服、保暖服等。

Suitable for splicing and reinforcing the seam of two pieces of general underwear, seaming at the bottom of men's underwear, strip reinforcement and patchwork for women's bodysuits, complete seaming of two-color fabrics, etc., such as: knitting, swimwear, yoga wear, thermal wear, etc.

机型 Model	针位组 Needle position group	针数 Number of needles	线数 Number of threads	修布刀 Cloth trimming knife	线迹长度 Stitch length (MM)	车缝布料 Sewing fabric	压脚高度 Presser foot height(MM)	最高转速 Max speed (S.P.M)	机针型号 Needle model	体积 Volume (CM)	重量 Weight (KG)
JK-8787E-01GB-356-UT2	356	3	5	★	4.5	薄 中厚 厚料 Thin, medium thick, thick material	10	4500	UV128GAS	71×39×64.5	64

JK-8787 E - 01GB - 356 - UT

①

②

③

④

⑤



扫一扫了解更多

步进一体自动剪线 小方头绷缝机

Step by step automatic thread cutting

Small cylinder bed interlock sewing machine

杰克牌8787小方头绷缝 Jack 8787 cylinder bed interlock	步进自动剪线 Step automatic thread trimming	普通缝 356 needle positions	356针位 356 needle positions	上剪线+下剪线+拨线(电动式) Up cutting+down cutting+wire pulling (electric type)
①	②	③	④	⑤
	可选常规款 Optional regular type	根据用户需求可选配刀组 Optional tool set according to user needs	根据样品、工艺可选配针位 Optional needle position according to the sample and process.	根据用户需求可选配配置 Optional configurations according to user needs



适用服装品类

Applicable clothing categories

适用于一般内衣裤二片布接缝处之拼接缝和补强、男用内裤底过骨拼缝，女用紧身衣裤贴条补强，拼缝，双色布料完全密合拼缝等，如：针织、泳装、瑜伽服、保暖服等。

Suitable for splicing and reinforcing the seam of two pieces of general underwear, seaming at the bottom of men's underwear, strip reinforcement and patchwork for women's bodysuits, complete seaming of two-color fabrics, etc., such as: knitting, swimwear, yoga wear, thermal wear, etc.

机型 Model	针位组 Needle position group	针数 Number of needles	线数 Number of threads	修布刀 Cloth trimming knife	线迹长度 Stitch length (MM)	车缝布料 Sewing fabric	压脚高度 Presser foot height(MM)	最高转速 Max speed (S.P.M)	机针型号 Needle model	体积 Volume (CM)	重量 Weight (KG)
JK-8787E-01GB-356-UT	356	3	5	★	4.5	薄 中厚 厚料 Thin, medium thick, thick material	10	4500	UV128GAS	71×39×64.5	64

JK-8787 E - 01GB - 356 - DT

①

②

③

④

⑤



扫一扫了解更多

步进一体自动剪线 小方头绷缝机

Step by step automatic thread cutting

Small cylinder bed interlock sewing machine

杰克牌8787小方头绷缝 Jack 8787 cylinder bed interlock	步进自动剪线 Step automatic thread trimming	普通缝 356 needle positions	356针位 356 needle positions	直驱式 Direct drive type
①	②	③	④	⑤
	可选常规款 Optional regular type	根据用户需求可选配刀组 Optional tool set according to user needs	根据样品、工艺可选配针位 Optional needle position according to the sample and process.	根据用户需求可选配配置 Optional configurations according to user needs



适用服装品类

Applicable clothing categories

适用于一般内衣裤二片布接缝处之拼接缝和补强、男用内裤底过骨拼缝，女用紧身衣裤贴条补强，拼缝，双色布料完全密合拼缝等，如：针织、泳装、瑜伽服、保暖服等。

Suitable for splicing and reinforcing the seam of two pieces of general underwear, seaming at the bottom of men's underwear, strip reinforcement and patchwork for women's bodysuits, complete seaming of two-color fabrics, etc., such as: knitting, swimwear, yoga wear, thermal wear, etc.

机型 Model	针位组 Needle position group	针数 Number of needles	线数 Number of threads	修布刀 Cloth trimming knife	线迹长度 Stitch length (MM)	车缝布料 Sewing fabric	压脚高度 Presser foot height(MM)	最高转速 Max speed (S.P.M)	机针型号 Needle model	体积 Volume (CM)	重量 Weight (KG)
JK-8787E-01GB-356-DT	356	3	5	★	4.5	薄 中厚 厚料 Thin, medium thick, thick material	10	4500	UV128GAS	71×39×64.5	64

JK-8787 - 35AC - 356 - UT2 - AW2S

①

②

③

④

⑤



扫一扫了解更多

步进一体自动剪线 小方头绷缝机

Step by step automatic thread cutting

Small cylinder bed interlock sewing machine

杰克牌8787小方头绷缝 Jack 8787 cylinder bed interlock	左修刀 With left knife	356针位 356 needle positions	下剪线+拨线器(电动式) Wire cutting+wire puller (electric type)	电动吸风装置 Electric suction device
①	②	③	④	⑤
	根据用户需求可选配刀组 Optional tool set according to user needs	根据样品、工艺可选配针位 Optional needle position according to the sample and process.	根据用户需求可选配配置 Optional configurations according to user needs	根据用户需求可选配配置 Optional configurations according to user needs



适用服装品类

Applicable clothing categories

适用于一般内衣裤二片布接缝处之拼接缝和补强、男用内裤裤底过骨拼缝，女用紧身衣裤贴条补强，拼缝，双色布料完全密合拼缝等，如：针织、泳装、瑜伽服、保暖服等。

Suitable for splicing and reinforcing the seam of two pieces of general underwear, seaming at the bottom of men's underwear, strip reinforcement and patchwork for women's bodysuits, complete seaming of two-color fabrics, etc., such as: knitting, swimwear, yoga wear, thermal wear, etc.

机型 Model	针位组 Needle position group	针数 Number of needles	线数 Number of threads	修布刀 Cloth trimming knife	线迹长度 Stitch length (MM)	车缝布料 Sewing fabric	压脚高度 Presser foot height(MM)	最高转速 Max speed (S.P.M)	机针型号 Needle model	体积 Volume (CM)	重量 Weight (KG)
JK-8787-35AC-356-UT2-AW2S	356	3	5	左修刀 Left knife	4.5	薄 中厚 厚料 Thin, medium thick, thick material	8	4500	UV128GAS	71×39×64.5	64

JK-8787 - 35AC - 356 - UT - AW1S

①

②

③

④

⑤



扫一扫了解更多

步进一体自动剪线 小方头绷缝机

Step by step automatic thread cutting

Small cylinder bed interlock sewing machine

杰克牌8787小方头绷缝机 Jack 8787 cylinder bed interlock	左修刀 With left knife	356针位 356 needle positions	上剪线+下剪线+拨线(电动式) Up cutting+down cutting+wire pulling (electric type)	气动吸风装置 Pneumatic suction device
①	②	③	④	⑤
	根据用户需求可选配刀组 Optional tool set according to user needs	根据样品、工艺可选配针位 Optional needle position according to the sample and process.	根据用户需求可选配配置 Optional configurations according to user needs	根据用户需求可选配配置 Optional configurations according to user needs



适用服装品类

Applicable clothing categories

适用于一般内衣裤二片布接缝处之拼接缝和补强、男用内裤裤底过骨拼缝，女用紧身衣裤贴条补强，拼缝，双色布料完全密合拼缝等，如：针织、泳装、瑜伽服、保暖服等。

Suitable for splicing and reinforcing the seam of two pieces of general underwear, seaming at the bottom of men's underwear, strip reinforcement and patchwork for women's bodysuits, complete seaming of two-color fabrics, etc., such as: knitting, swimwear, yoga wear, thermal wear, etc.

机型 Model	针位组 Needle position group	针数 Number of needles	线数 Number of threads	修布刀 Cloth trimming knife	线迹长度 Stitch length (MM)	车缝布料 Sewing fabric	压脚高度 Presser foot height(MM)	最高转速 Max speed (S.P.M)	机针型号 Needle model	体积 Volume (CM)	重量 Weight (KG)
JK-8787-35AC-356-UT-AW1S	356	3	5	左修刀 Left knife	4.5	薄 中厚 厚料 Thin, medium thick, thick material	8	4500	UV128GAS	71×39×64.5	64

JK-8787 - 33AC - 356 - UT2 - AW2S

①

②

③

④

⑤



扫一扫了解更多

步进一体自动剪线 小方头绷缝机

Step by step automatic thread cutting

Small cylinder bed interlock sewing machine

杰克牌8787小方头绷缝 Jack 8787 cylinder bed interlock	右修刀 With right knife	356针位 356 needle positions	下剪线+拨线器(电动式) Wire cutting+wire puller (electric type)	电动吸风装置 Electric suction device
①	②	③	④	⑤
	根据用户需求可选配刀组 Optional tool set according to user needs	根据样品、工艺可选配针位 Optional needle position according to the sample and process.	根据用户需求可选配配置 Optional configurations according to user needs	根据用户需求可选配配置 Optional configurations according to user needs



适用服装品类

Applicable clothing categories

适用于一般内衣裤二片布接缝处之拼接缝和补强、男用内裤底过骨拼缝，女用紧身衣裤贴条补强，拼缝，双色布料完全密合拼缝等，如：针织、泳装、瑜伽服、保暖服等。

Suitable for splicing and reinforcing the seam of two pieces of general underwear, seaming at the bottom of men's underwear, strip reinforcement and patchwork for women's bodysuits, complete seaming of two-color fabrics, etc., such as: knitting, swimwear, yoga wear, thermal wear, etc.

机型 Model	针位组 Needle position group	针数 Number of needles	线数 Number of threads	修布刀 Cloth trimming knife	线迹长度 Stitch length (MM)	车缝布料 Sewing fabric	压脚高度 Presser foot height(MM)	最高转速 Max speed (S.P.M)	机针型号 Needle model	体积 Volume (CM)	重量 Weight (KG)
JK-8787-33AC-356-UT2-AW2S	356	3	5	右修刀 Right knife	4.5	薄 中厚 厚料 Thin, medium thick, thick material	8	4500	UV128GAS	71×39×64.5	64

JK-8787 - 33AC - 356 - UT - AW1S

①

②

③

④

⑤



扫一扫了解更多

步进一体自动剪线 小方头绷缝机

Step by step automatic thread cutting

Small cylinder bed interlock sewing machine

杰克牌8787小方头绷缝 Jack 8787 cylinder bed interlock	右修刀 With right knife	356针位 356 needle positions	上剪线+下剪线+拨线(电动式) Up cutting+down cutting+wire pulling (electric type)	气动吸风装置 Pneumatic suction device
①	②	③	④	⑤
	根据用户需求可选配刀组 Optional tool set according to user needs	根据样品、工艺可选配针位 Optional needle position according to the sample and process.	根据用户需求可选配配置 Optional configurations according to user needs	根据用户需求可选配配置 Optional configurations according to user needs



适用服装品类

Applicable clothing categories

适用于一般内衣裤二片布接缝处之拼接缝和补强、男用内裤裤底过骨拼缝，女用紧身衣裤贴条补强，拼缝，双色布料完全密合拼缝等，如：针织、泳装、瑜伽服、保暖服等。

Suitable for splicing and reinforcing the seam of two pieces of general underwear, seaming at the bottom of men's underwear, strip reinforcement and patchwork for women's bodysuits, complete seaming of two-color fabrics, etc., such as: knitting, swimwear, yoga wear, thermal wear, etc.

机型 Model	针位组 Needle position group	针数 Number of needles	线数 Number of threads	修布刀 Cloth trimming knife	线迹长度 Stitch length (MM)	车缝布料 Sewing fabric	压脚高度 Presser foot height(MM)	最高转速 Max speed (S.P.M)	机针型号 Needle model	体积 Volume (CM)	重量 Weight (KG)
JK-8787-33AC-356-UT-AW1S	356	3	5	右修刀 Right knife	4.5	薄 中厚 厚料 Thin, medium thick, thick material	8	4500	UV128GAS	71×39×64.5	64

超细嘴绷缝系列 — 编码规则

Ultra small mouth interlock machine series — Coding rules



JK - 8770E - 01G B - 3 56 - UT2 -

品牌 Brand	间隔 Interval	主型号 Main model	间隔 Interval	特征1 Feature 1	特征2 Feature 2	间隔 Interval	针数 Needle	针距 Needle distance	间隔 Interval	选配 Optional	间隔 Interval	装置 Device
-------------	----------------	-------------------	----------------	------------------	------------------	----------------	--------------	-----------------------	----------------	----------------	----------------	--------------

① 品牌 Brand	杰克
JK	杰克

② 主型号 Main model	普通缝 Ordinary seam
8770	普通缝 Ordinary seam
8770E	步进款 Stepping type

③ 特征1 Feature 1	普通缝 Ordinary seam
01G	普通缝 Ordinary seam
02B	包边缝 Edge covering sewing
35A	带左切刀 With left cutting blade
33A	带右切刀 With right cutting blade

④ 特征2 Feature 2	针板小舌头后面长度为标准的 The length behind the small tongue of the needle board is standard
B	针板小舌头后面长度为标准的 The length behind the small tongue of the needle board is standard
C	针板小舌头后面长度为长的 The length behind the small tongue of the needle board is long

⑤ 针数 Needle	2针/2 needle
2	2针/2 needle
3	3针/3 needle
4	4针/4 needle

⑥ 针距 Needle distance	宽(width) 4.0mm
40	宽(width) 4.0mm
48	宽(width) 4.8mm
56	宽(width) 5.6mm
60	宽(width) 6.0mm
64	宽(width) 6.4mm

⑦ 辅助装置 Auxiliary device	直驱式 Direct drive type
D	直驱式 Direct drive type
UT	上剪线+下剪线+拨线(电动式) Up cutting+down cutting+wire pulling (electric type)
UT2	下剪线+拨线器(电动式) Wire cutting+wire puller (electric type)
UT3	下剪线+上剪线(电动式) Lower cutting line+upper cutting line (electric type)
UTL	上剪线+下剪线+拨线(气动式) Upper wire cutting+lower wire cutting+wire pulling (pneumatic)

⑧ 辅助装置 Auxiliary device	后拖轮装置(齿轮) Rear towing device (gear)
PL	后拖轮装置(齿轮) Rear towing device (gear)
PR	后拖轮装置(平轮) Rear towing device (flat wheel)
F	上裤腰装置 Upper waistband device
AW1S	气动吸风装置(左、右切刀专用) Pneumatic suction device (dedicated for left and right cutting blades)
AW2S	电动吸风装置(左、右切刀专用) Electric suction device (dedicated for left and right cutting blades)

超细嘴绷缝系列 — 功能介绍

Ultra small mouth interlock machine series — Function introduction



扫一扫了解更多

5 6 针头: 356常规 Needle: 356 regular

1 品牌: 杰克 Brand: Jack

2 型号牌: JK-8770E-01GB-356-UT2

7 8 UT2: 下剪线+拨线器(电动式) Wire cutting+wire puller (electric type)



产品特征/Product features

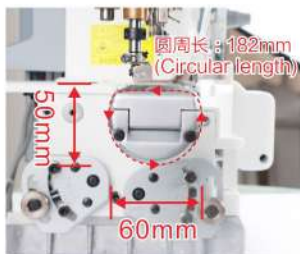

细筒型设计
Slim barrel design



短横筒设计
Short horizontal tube design



步进电机, 操作方便
Stepper motor, easy to operate



微调式底线切刀组
Fine tuned bottom line cutter set

JK-8770 E - 01GB - 356 - UT2

①

②

③

④

⑤



扫一扫了解更多

步进一体自动剪线 小方头绷缝机

Step by step automatic thread cutting

Small cylinder bed interlock sewing machine

杰克牌8770超细嘴绷缝 Jack 8770 ultra small mouth interlock	步进自动剪线 Step automatic thread trimming	普通缝 356 needle positions	356针位 356 needle positions	下剪线+拨线器(电动式) Wire cutting+wire puller (electric type)
①	②	③	④	⑤
	可选常规款 Optional regular type	根据用户需求可选配刀组 Optional tool set according to user needs	根据样品、工艺可选配针位 Optional needle position according to the sample and process.	根据用户需求可选配配置 Optional configurations according to user needs



适用服装品类

Applicable clothing categories

适用于一般内衣裤二片布接缝处之拼接缝和补强、男用内裤底过骨拼缝，女用紧身衣裤贴条补强，拼缝，双色布料完全密合拼缝等，如：针织、泳装、瑜伽服、保暖服等。

Suitable for splicing and reinforcing the seam of two pieces of general underwear, seaming at the bottom of men's underwear, strip reinforcement and patchwork for women's bodysuits, complete seaming of two-color fabrics, etc., such as: knitting, swimwear, yoga wear, thermal wear, etc.

机型 Model	针位组 Needle position group	针数 Number of needles	线数 Number of threads	修布刀 Cloth trimming knife	线迹长度 Stitch length (MM)	车缝布料 Sewing fabric	压脚高度 Presser foot height(MM)	最高转速 Max speed (S.P.M)	机针型号 Needle model	体积 Volume (CM)	重量 Weight (KG)
JK-8770E-01GB-356-UT2	356	3	5	★	4.5	薄 中厚 厚料 Thin, medium thick, thick material	10	4500	UV128GAS	71×39×64.5	64

JK-8770 E - 01GB - 356 - UT

①

②

③

④

⑤



扫一扫了解更多

步进一体自动剪线 小方头绷缝机

Step by step automatic thread cutting

Small cylinder bed interlock sewing machine

杰克牌8770超细嘴绷缝 Jack 8770 ultra small mouth interlock	步进自动剪线 Step automatic thread trimming	普通缝 356 needle positions	356针位 356 needle positions	上剪线+下剪线+拨线(电动式) Up cutting+down cutting+wire pulling (electric type)
①	②	③	④	⑤
	可选常规款 Optional regular type	根据用户需求可选配刀组 Optional tool set according to user needs	根据样品、工艺可选配针位 Optional needle position according to the sample and process.	根据用户需求可选配配置 Optional configurations according to user needs



适用服装品类

Applicable clothing categories

适用于一般内衣裤二片布接缝处之拼接缝和补强、男用内裤裤底过骨拼缝，女用紧身衣裤贴条补强，拼缝，双色布料完全密合拼缝等，如：针织、泳装、瑜伽服、保暖服等。

Suitable for splicing and reinforcing the seam of two pieces of general underwear, seaming at the bottom of men's underwear, strip reinforcement and patchwork for women's bodysuits, complete seaming of two-color fabrics, etc., such as: knitting, swimwear, yoga wear, thermal wear, etc.

机型 Model	针位组 Needle position group	针数 Number of needles	线数 Number of threads	修布刀 Cloth trimming knife	线迹长度 Stitch length (MM)	车缝布料 Sewing fabric	压脚高度 Presser foot height(MM)	最高转速 Max speed (S.P.M)	机针型号 Needle model	体积 Volume (CM)	重量 Weight (KG)
JK-8770E-01GB-356-UT	356	3	5	★	4.5	薄 中厚 厚料 Thin, medium thick, thick material	10	4500	UV128GAS	71×39×64.5	64

JK-8770 E - 01GB - 356 - DT

①

②

③

④

⑤



扫一扫了解更多

步进一体自动剪线 小方头绷缝机

Step by step automatic thread cutting

Small cylinder bed interlock sewing machine

杰克牌8770超细嘴绷缝 Jack 8770 ultra small mouth interlock	步进自动剪线 Step automatic thread trimming	普通缝 356 needle positions	356针位 356 needle positions	直驱式 Direct drive type
①	②	③	④	⑤
	可选常规款 Optional regular type	根据用户需求可选配刀组 Optional tool set according to user needs	根据样品、工艺可选配针位 Optional needle position according to the sample and process.	根据用户需求可选配配置 Optional configurations according to user needs



适用服装品类

Applicable clothing categories

适用于一般内衣裤二片布接缝处之拼接缝和补强、男用内裤底过骨拼缝，女用紧身衣裤贴条补强，拼缝，双色布料完全密合拼缝等，如：针织、泳装、瑜伽服、保暖服等。

Suitable for splicing and reinforcing the seam of two pieces of general underwear, seaming at the bottom of men's underwear, strip reinforcement and patchwork for women's bodysuits, complete seaming of two-color fabrics, etc., such as: knitting, swimwear, yoga wear, thermal wear, etc.

机型 Model	针位组 Needle position group	针数 Number of needles	线数 Number of threads	修布刀 Cloth trimming knife	线迹长度 Stitch length (MM)	车缝布料 Sewing fabric	压脚高度 Presser foot height(MM)	最高转速 Max speed (S.P.M)	机针型号 Needle model	体积 Volume (CM)	重量 Weight (KG)
JK-8770E-01GB-356-DT	356	3	5	★	4.5	薄 中厚 厚料 Thin, medium thick, thick material	10	4500	UV128GAS	71×39×64.5	64

JK-8770 - 35AC - 356 - UT2 - AW2S

①

②

③

④

⑤



扫一扫了解更多

电脑横筒式左修刀 超小嘴绷缝机

Computer horizontal cylinder left trimmer

Super small mouth interlock sewing machine

杰克牌8770超细嘴绷缝 Jack 8770 ultra small mouth interlock	左修刀 With left knife	356针位 356 needle positions	下剪线+拨线器(电动式) Wire cutting+wire puller (electric type)	电动吸风装置 Electric suction device
①	②	③	④	⑤
	小嘴只有左刀 The small mouth only has a left knife	根据样品、工艺可选配针位 Optional needle position according to the sample and process.	根据用户需求可选配配置 Optional configurations according to user needs	根据用户需求可选配配置 Optional configurations according to user needs



适用服装品类

Applicable clothing categories

适用于一般内衣裤二片布接缝处之拼接缝和补强、男用内裤底过骨拼缝, 女用紧身衣裤贴条补强, 拼缝, 双色布料完全密合拼缝等, 如: 针织、泳装、瑜伽服、保暖服等。

Suitable for splicing and reinforcing the seam of two pieces of general underwear, seaming at the bottom of men's underwear, strip reinforcement and patchwork for women's bodysuits, complete seaming of two-color fabrics, etc., such as: knitting, swimwear, yoga wear, thermal wear, etc.

机型 Model	针位组 Needle position group	针数 Number of needles	线数 Number of threads	修布刀 Cloth trimming knife	线迹长度 Stitch length (MM)	车缝布料 Sewing fabric	压脚高度 Presser foot height(MM)	最高转速 Max speed (S.P.M)	机针型号 Needle model	体积 Volume (CM)	重量 Weight (KG)
JK-8770-35AC-356-UT2-AW2S	356	3	5	左修刀 Left knife	4.5	薄 中厚 厚料 Thin, medium thick, thick material	8	4500	UV128GAS	71×39×64.5	64

JK-8770 - 35AC - 356 - UT - AW1S

①

②

③

④

⑤



扫一扫了解更多

电脑横筒式左修刀 超小嘴绷缝机

Computer horizontal cylinder left trimmer

Super small mouth interlock sewing machine

杰克牌8770超细嘴绷缝 Jack 8770 ultra small mouth interlock	左修刀 With left knife	356针位 356 needle positions	上剪线+下剪线+拨线(电动式) Up cutting+down cutting+wire pulling (electric type)	气动吸风装置 Pneumatic suction device
①	②	③	④	⑤
	小嘴只有左刀 The small mouth only has a left knife	根据样品、工艺可选配针位 Optional needle position according to the sample and process.	根据用户需求可选配配置 Optional configurations according to user needs	根据用户需求可选配配置 Optional configurations according to user needs



适用服装品类

Applicable clothing categories

适用于一般内衣裤二片布接缝处之拼接缝和补强、男用内裤裤底过骨拼缝，女用紧身衣裤贴条补强，拼缝，双色布料完全密合拼缝等，如：针织、泳装、瑜伽服、保暖服等。

Suitable for splicing and reinforcing the seam of two pieces of general underwear, seaming at the bottom of men's underwear, strip reinforcement and patchwork for women's bodysuits, complete seaming of two-color fabrics, etc., such as: knitting, swimwear, yoga wear, thermal wear, etc.

机型 Model	针位组 Needle position group	针数 Number of needles	线数 Number of threads	修布刀 Cloth trimming knife	线迹长度 Stitch length (MM)	车缝布料 Sewing fabric	压脚高度 Presser foot height(MM)	最高转速 Max speed (S.P.M)	机针型号 Needle model	体积 Volume (CM)	重量 Weight (KG)
JK-8770-35AC-356-UT-AW1S	356	3	5	左修刀 Left knife	4.5	薄 中厚 厚料 Thin, medium thick, thick material	8	4500	UV128GAS	71×39×64.5	64



杰克缝纫机官方微信



杰克缝纫机官方抖音

400-8876-858
www.chinajack.com

杰克科技股份有限公司
浙江省台州市椒江区东海大道东段1008号
电话 :0086-576-88177788 88177789
传真 :0086-576-88177758

JACK TECHNOLOGY CO.,LTD
No.1008, Donghai Road East, Jiaojiang District,
Taizhou city, Zhejiang, China
TEL:0086-576-88177788 88177789
FAX:0086-576-88177758